

GOJAK[®]

VEHICLE MOVERS BY SERENCO



SERENCO
SERIOUS TOOLS SERIOUS RESULTS

EN CATALOG
2024

GoJak®

GoJak® has been designed to improve on vehicle movement and repositioning in work shops, showrooms and body shops but is also valuable in car parks and to a multitude of rescue services. To overcome different axle widths, wheelbases, wheel sizes and tyre widths every GoJak® is self-loading. This system makes lifting and moving vehicles in any direction very quick and easy saving both time and money. With the 5 models available an immense range of vehicles weighing up to 3.180 kg can be 'lifted & shifted'.

All GoJak® products are designed, tested, and manufactured in the USA for years of dependability.

Serenco has been around for more than 35 years and that is not without a reason:

- Serenco is a leading supplier of professional tools and equipment
- For the automotive and bicycle market and the industrial environment
- More than 2.500 high quality products in stock
- Fast delivery from our central warehouse to customers in over 48 countries
- All Serenco employees are knowledgeable, service-oriented and above all: proud!

**LET'S
GET
SERIOUS.**

GOJAK®
VEHICLE MOVERS BY SERENCO

What makes GoJak® products so special?

The colour, of course, is so distinctive that you can recognise them from far away. Then there is the quality. All parts of the GoJak® are carefully designed and manufactured. With three goals: Safety, quality and durability. A short explanation:

Position broken down cars with ease

Features include directional lever, high strength galvanized steel rollers, upgraded 44.5 mm wide axles, and heavy-duty nylon, double-ball bearing raceway casters, available in a left and right handle version. This set up makes for smooth rolling under heavier loads and easy to manoeuvre a vehicle in the right place.

4 ~ 5 pumps

GoJak® opens and closes easily to surround the tire in seconds. Ratcheting mechanism only take 4 ~ 5 pumps to get the tire only a few centimeters off the ground.



Steel pedal

Mechanical leverage applied to the foot pedal progressively 'squeezes' the vehicle tire between the rollers until the tire lifts smoothly off the ground.



GoJak® only contacts the tire

The rollers touch only the tire, no contact with the vehicle's frame or undercarriage is necessary.



Bi-directional ratches

The built in bi-directional ratches cycles both up and down one controlled click at a time.



High quality casters

Heavy-duty nylon, double-ball bearing raceway casters.



Steel rollers

High strength galvanized steel rollers.



Right- and left-handed model

Standard GoJaks® are right-handed. When you insert the jack around the tire, the pedal is mounted on the left and rises to the right. Left hand units are the opposite. This reverse position may be important when the vehicle is locked or broken down with broken steering rods due to an accident. In these circumstances, use of the foot pedal may prove more difficult. With left and right GoJaks®, you can position the appropriate unit so the pedal is more accessible. For normal shop use, left hand units are not necessary. Standard right hand units are shipped unless you specify a left hand unit.



Vehicle mover - Sports car model

G4520 (right hand)

The American-Made GoJak® wheel dolly G4520 was developed for the racing car industry. Cars with tyre widths from 125 mm to 508 mm can be moved effortlessly. The device is designed for vehicle weights up to 2 tons. Twin rollers on each axle guide the tire smoothly up and over the axle support bar to lift wider tyres. This car dolly uses a bi-directional linear ratchet for the jack portion and has a 5-degree offset pedal angle for additional foot-to-tire clearance.

- Max. 510 kg per GoJak® (2,040 kg per 4 units)
- Tyre widths max. 508 mm
- 4 Double steel rollers
- 4 Casters ANSI ICWM 2012 Certified
- 1 unit per box (right hand only)
- 19.5 kg

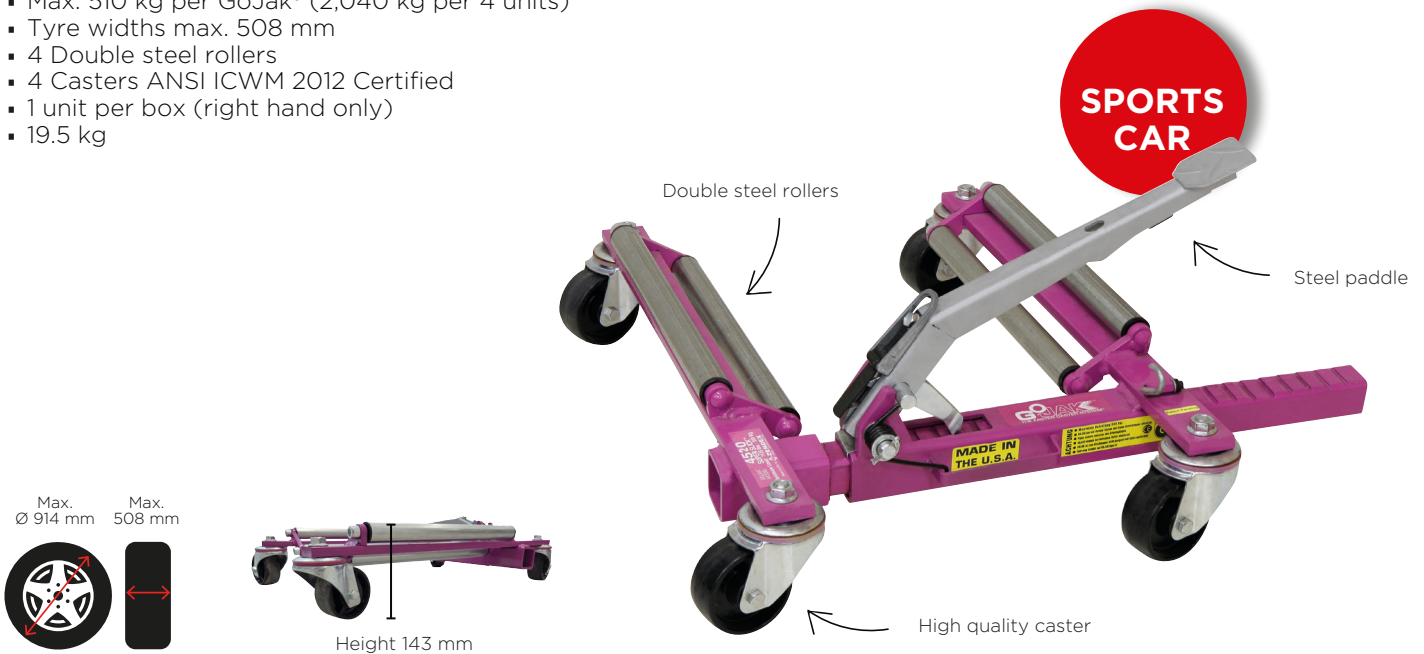

Vehicle mover - HD Hybrid (EV) sports car model

G6520 (right hand)

The American-Made GoJak® wheel dolly G6520 was developed for the hybrid and EV cars. Cars with tyre widths from 125 mm to 508 mm can be moved effortlessly. The device is designed for vehicle weights up to 3 tons. Twin rollers on each axle guide the tire smoothly up and over the axle support bar to lift wider tyres. This car dolly uses a bi-directional linear ratchet for the jack portion and has a 5-degree offset pedal angle for additional foot-to-tire clearance.

- Max. 816 kg per GoJak® (3,264 kg per 4 units)
- Tyre widths max. 508 mm
- 4 Double steel rollers
- 6 Casters ANSI ICWM 2012 Certified
- 1 Unit per box (right hand only)
- 23 kg

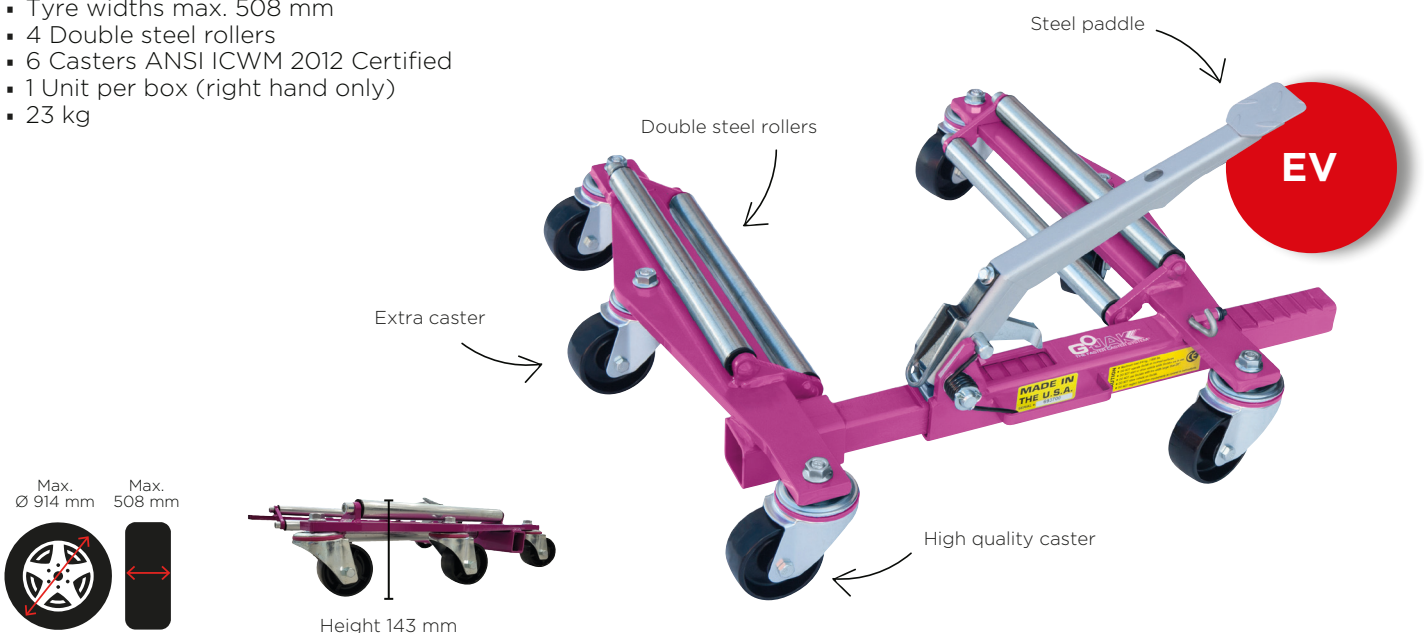

Vehicle mover

G6313 (right hand) / G6313L (left hand)

Easily position locked, blocked or disabled vehicles with the American-Made GoJak® wheel dolly. Use it in your shop, parking garage, or on a tow call. The G6313 is an absolute work horse rated for vehicle weights up to 2,860 kg and tire widths up to 330 mm. Features include high strength steel rollers, upgraded 44.5 mm axles, and heavy-duty, double-bal bearing raceway casters. This set up makes for smooth rolling under heavier loads. The G6313 also has a 5-degree offset pedal for additional foot-to-tire clearance when jacking. Equipped with the largest casters in the GoJak® product line allows for increased ground clearance, especially useful when pulling cars up a flatbed.

- Max. 715 kg per GoJak® (2,860 kg per 4 units)
- Tyre widths Max. 330 mm
- 2 Steel rollers
- 4 Casters ANSI ICWM 2012 Certified
- 17.5 kg
- Ideal for cobble stones floors

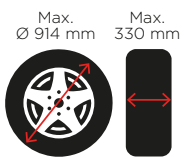

THE HEIGHT OF THE GOJAKS

Contrary to what some ‘experts’ claim, GoJak’s fit 99% of cars in terms of height. Only in extreme cases (super- and hypercars) is it advisable to opt for the G4520 and G6520, and we advise testing before actual purchase.

Vehicle mover - HD / suitable for dual wheels

G7016 (right hand)

Introducing the newest member of the American-Made GoJak® wheel dolly family, the GoJak® SUV™ model GH7016. Equipped with four super-heavy duty G.F. nylon casters (ANSI ICWM-2012 certified) and a unique steel roller design, G7016 pushes the limits of what can be moved with an auto-positioning dolly. Designed specifically to handle light commercial vehicles, trucks and SUV's (up to 3,180 kg) in your shop with ease.

With the G7016 SUV model we have taken our customers input and designed a truly revolutionary product built specifically to accommodate today's larger vehicles. The GoJak® Faster Caster System®, there is no better value.

- Max. 795 kg per GoJak® (3,180 kg per 4 units)
- Tyre widths max. 406 mm
- 4 Double steel rollers
- 4 Casters ANSI ICWM 2012 Certified
- 24 kg

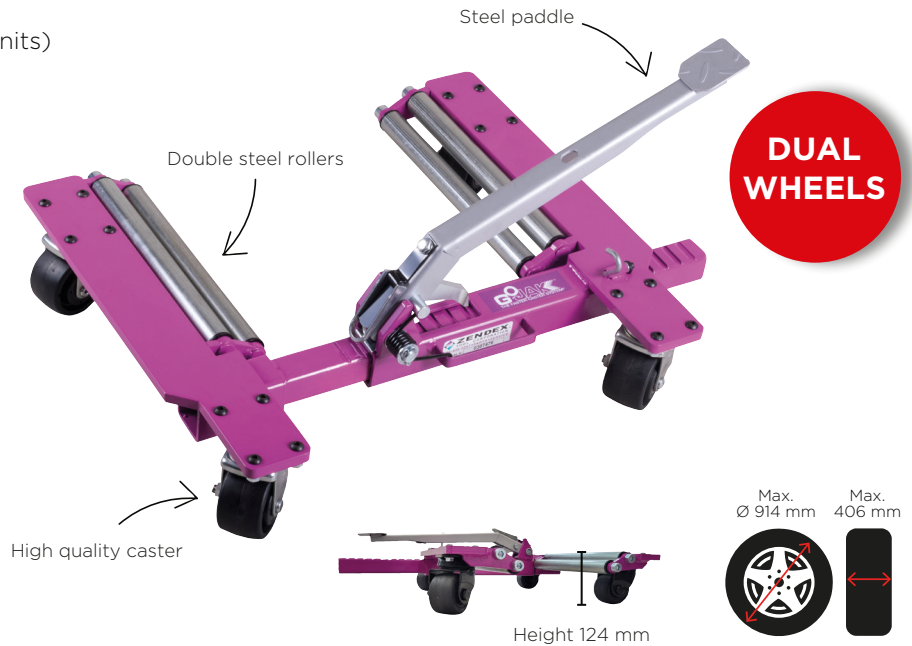

Vehicle mover

G5211 (right hand) / G5211L (left hand)

The model G5211 is the workhorse of the American-Made GoJak® wheel dolly family, product line. The basic self-loading dolly design was developed thirty years ago and the specifications have recently been improved to 590 kg capacity. The G5211 is a proven and reliable product that can lift and move wheel weights max. 590 kg per Gojak (2360 kg per 4 units). The unit accommodates a very large percentage of the passenger cars and small trucks sold today. It uses a bi-directional linear ratchet for the jack portion and four 4-inch diameter heavy-duty double ball raceway casters. Available in standard right and left version.

Left GoJak® unit only needed if vehicles front wheel is turned very sharply and the vehicle is locked or disabled.

- Max. 590 kg per GoJak® (2,360 kg per 4 units)
- Tyre widths Max. 279 mm
- 2 Steel rollers
- 4 Casters ANSI ICWM 2012 Certified
- 13.7 kg

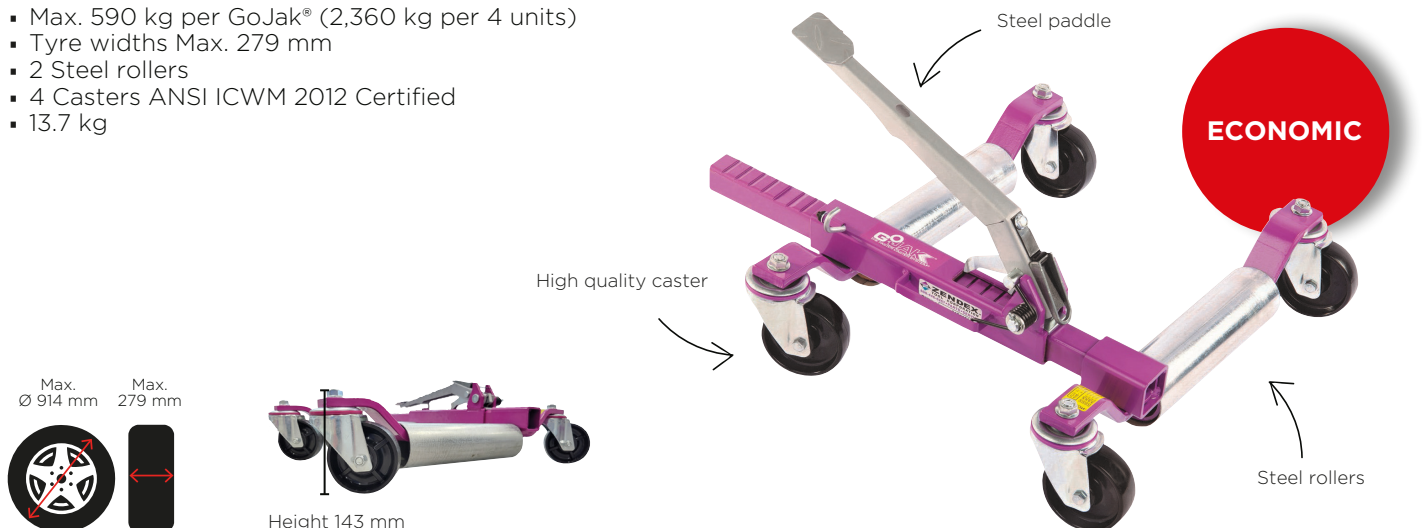

Aviation mover - light aircraft model

G4107 (right hand) / G4107L (left hand)

The American-Made GoJak® wheel dolly model G4107 is the perfect tool for self loading smaller wheel assemblies primarily found on light aircraft. The extreme angle of the handle allows for maximum clearance from body parts and fender covers. Hand operation enables you to easily use directly under wings where pedal operation would be more difficult.

The build in linear ratchet provides smooth and controlled lifting and lowering of tires. The unit uses 4x 75 mm double ball bearing raceway casters and is available in right and left hand configurations.

- Max. 465 kg per GoJak® (1,860 kg per 4 units)
- Tyre widths Max. 178 mm
- 4 Double steel rollers
- 4 Casters ANSI ICWM 2012 Certified
- 18.5 kg



GoJak® rack

G567R

Stores 4 GoJaks® in a convenient and orderly manner. Suitable for all GoJak® models and capable of storing up to four GoJaks®. They can easily roll to the job or storage area and will load and unload in seconds.

- Fits any combination of model or variation of GoJak® self-loading wheel dolly
- High quality TPR tread casters making it easy to roll your GoJaks® to the work area
- Robotically welded high quality American steel construction



Tow Truck mount bracket

GJGOTOW

The GoJak® truck mount bracket conveniently stores your GoJak® until needed. The self-locking ratchet design insures your GoJaks® stay in place and a convenient padlock bracket is provided to prevent theft.

- For use with all models
- Mounting hardware included

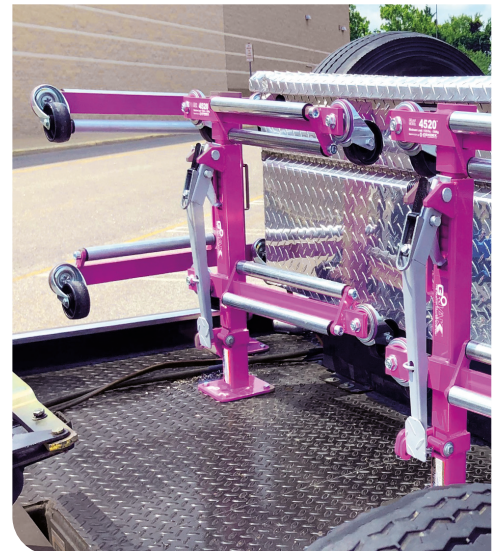
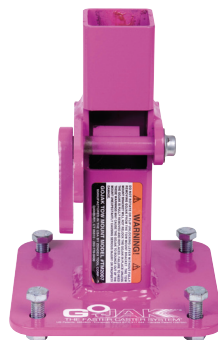

Wall-mount bracket

GJGOBKT

Convenient wall-mount bracket to keep your GoJak® off the floor and accessible. Organize your shop with these handy brackets. The rubber padding grips RakJak handle safely Rugs and screws are included for masonry mounting.

- Easily Store RakJak™ up and out of the way
- Fits all models



SERENCO

SERIOUS TOOLS SERIOUS RESULTS

This brochure is an edition of Serenco Nederland B.V.
Positronweg 12 • 3542 AZ UTRECHT • Tel. +31 (0)30 2415011 • www.serenco.com • sales@serenco.nl

Serenco Nederland reserves the right to change any specifications without prior notice. Images and specifications are made in good faith and are subject to change. Stock is subject to availability, products may be discontinued at any time.

EN_V2_2024/07

DEALER