

SURFACE MOUNTED

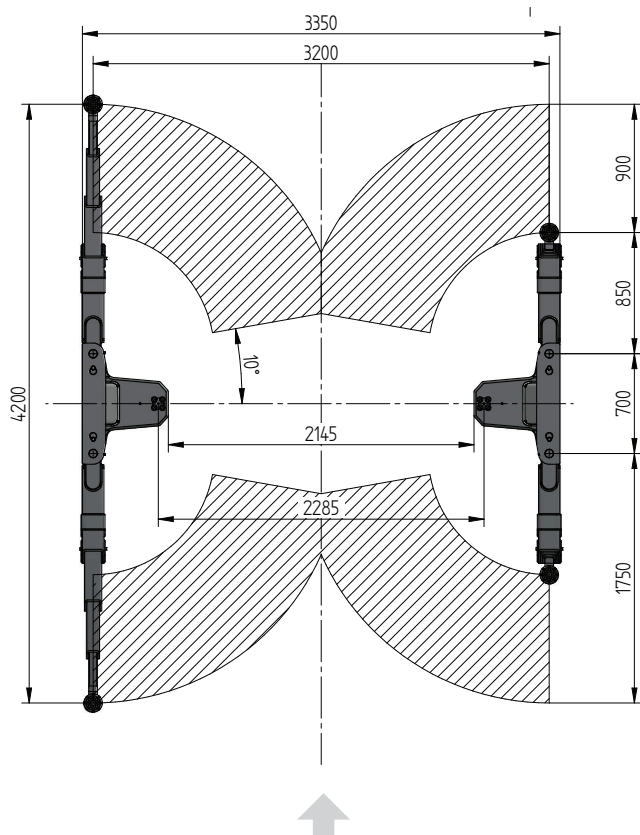
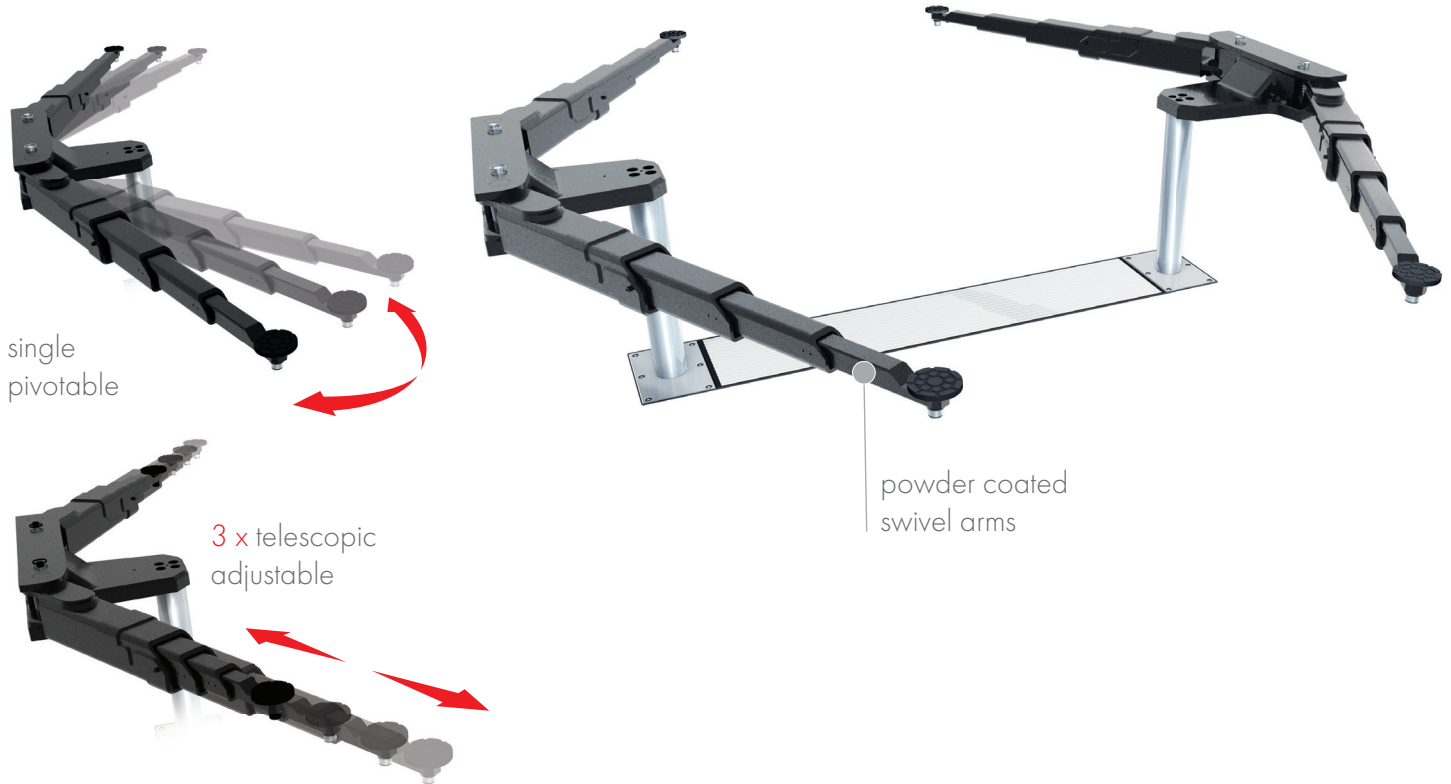

TECHNICAL DATA

Capacity	5000 kg
Effective raise height	2037 mm
Move in height	120 mm
Piston diameter	123 mm
Piston distance	2285 mm
Installation depth	2408 mm
Motor output	3,0 kW
Power connector	400 V/16 A
Cable length to control	11 m
Lifting time	≈ 35 sec.
Lowering time	≈ 35 sec.

Support Swingarm 2.50	112113
Installation cassette STEEL 2285 mm	2320XX
Installation cassette STEEL 2285 mm galvanized	2321XX
Lifting unit oil 5,0 t 2285 mm - K pre-assembled in installation cassette	111625
Lifting unit oil 5,0 t 2285 mm - H packed in wooden box	111626

ACCESSORIES

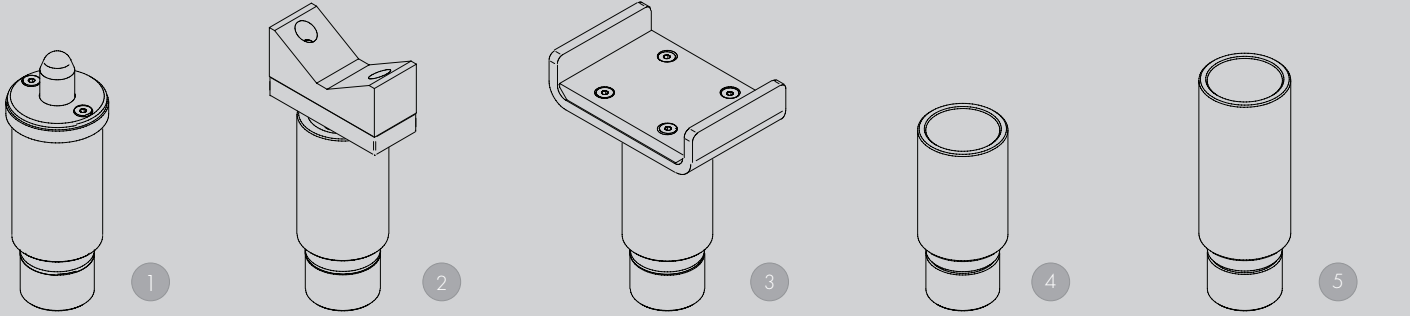

1 | Stacking adapter NCV3
d 50 x d 70 / 115-215 mm
112100 (1 set / 2 pcs.)

2 | Stacking adapter V-prism
d 50 / 87-130 mm
109683 (1 set / 2 pcs.)

3 | Stacking adapter U-form
d 50
1103976 (1 set / 4 pcs.)

4 | Stacking adapter extension
89 mm
109679 (1 set / 4 pcs.)

5 | Stacking adapter extension
127 mm
109680 (1 set / 4 pcs.)

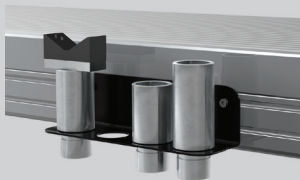

Bracket for stacking-
adapter extension
111578

Herrmann AG
Bahnhofstrasse 32
D-93483 Pöding

+49 (0)9461/91388 50
sales@herrmann-lifts.com
www.herrmann-lifts.com